

TYRE CHANGER
INSTRUCTION & MAINTENANCE MANUAL

We follow the way that wheel moving!



TYRE CHANGER INSTRUCTION MANUAL

INDEX	PAGE
1. Introduction:.....	2
2. Safety Warnings:.....	2
3. Technical data	3
4. Transport:.....	3
5. Unpacking & Inspection:.....	3
6. Workplace requirements:.....	3
7. Position and installation:.....	4
8. Electricity and Pneumatic connections:.....	4
9. Adjusting operation:.....	4
9.1. Breaking the tyre bead:	5
9.2. Demounting the tyre :	5
9.3. Mounting the tyre :.....	6
10. Help Arm 007B.....	6
10.1. Technical Data	6
10.2. Safety Regulations	6
10.3. Installation	6
10.3.1. Transport	6
10.3.2. Unpacking.....	7
10.3.3. Workplace Requirement.....	7
10.3.4 Assembly.....	7
10.4. Functional Parts	7
10.5. Trial operation.....	7
10.6. Operations.....	8
10.6.1. Fixing The Tire (function of central positioning).....	8
10.6.2. Demounting The Tire.....	8
10.6.3. Mounting the tire.....	9
11. Inflating the tire :.....	10
12. Moving machine:.....	10
13. Maintenance:.....	10
14. Rapid tyre inflation system (only suitable for the IT-suffix version machine):.....	11
14.1. Rapid Tire Inflation Device:	11
14.2. Wheel rim lock and Tire inflation:.....	12
14.3. Inflation for tire with inner tube:.....	12
14.4. Inflation for tubeless tire:.....	12
15. Trouble shooting table:	13
16. Guide for ordering spare parts	13
17. Wearing spare parts list.....	14
18. Exploded drawing:.....	15
19. Circuit diagram:.....	29
20. Pneumatic drawing:.....	29

Tyre Changer

Warning

This instruction manual is important for the machine, please read carefully before installation and use; also it is important for safe use and machine maintenance of machine. Please keep this manual properly in order to further maintenance of the machine.

1. Introduction:

Application Range: The automatic tyre changer is especially designed for demounting / mounting tyres from wheel rims.

Caution: Please use the machine only for purpose for which it is designed, don't use it for other purposes.

Manufacturer shall not be liable for any damage or injury caused by failure to comply with these regulations.

Safety regulation: Use of this machine is especially reserved to trained and qualified professional persons, those who already read the introduction manual carefully, or someone have the experience for operating similar machinery. Any changes and beyond the scope of use on this machine without manufacturer's permission or do not according to the manual, may cause the malfunction and damage to machine, manufacturer can cancel warranty coverage for above. If some parts are damaged due to some reason, please replace them according to the spare parts list. (Attention: warranty is one year after manufactures' delivery date; warranty excludes the easy-broken parts)

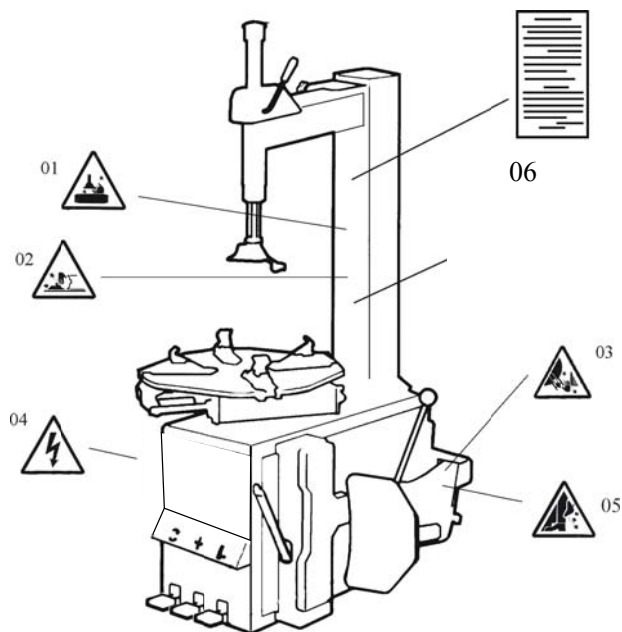

2. Safety Warnings:

- 01 Don't put hands under the Mounting head/demounting head during operation;
- 02 Don't put hands between the jaws during operation;
- 03 Don't put hands in the tyre bead when demounting the tyre;
- 04 Make sure and to check the system is equipped with a good grounding circuit;
- 05 Don't put feet between the Bead Breaker shovel and the body during operation;
- 06 Warning instruction

Security warning labels

Caution:

When the security warning labels are defaced or off, please recovery them in time!

Do not allow to operate when the security warning labels are missed or imperfect.

Do not allow to set any objects to obscure the security warning labels.

Clients can self-set the warning labels (as right picture show) at any necessary positions.



3. Technical data

External locking rim dimensions	10~21 "
Internal locking rim dimensions	12~24 "
Max. Wheel diameter	1000mm (40 ")
Max. Wheel width	355mm(14 ")
Working Pressure	8-10bar
Power supply	110V (1ph)/ 220V (1ph)/ 380V (3ph)
Optional Motor power	0.75/0.55/1.1 kw
Max. Rotating Torque (Turntable)	1078 N•m
Overall Dimension	960*760*930 mm
Noise Level	<75 dB

Remark:

Rim dimensions defined at above table are based on the iron wheel rims. Aluminum rims are thicker than the iron wheel rims, so here above rim dimensions are just for the reference.

4. Transport:

When transporting, the machine should be with original package and placed according to the mark on the package. For the already packaged machine should be handled with a corresponding tonnage forklift for loading and unloading. The location to insert the fork feet shown as **Fig 1**

5. Unpacking & Inspection:

Pull out the nail which is nailed on the plate with tip jaw; unpack the carton and plastic cover. Check and make sure all parts shown on the spare parts list are included. If any parts are missing or broken, please do not use the machine and contact the manufacturer or dealer ASAP.

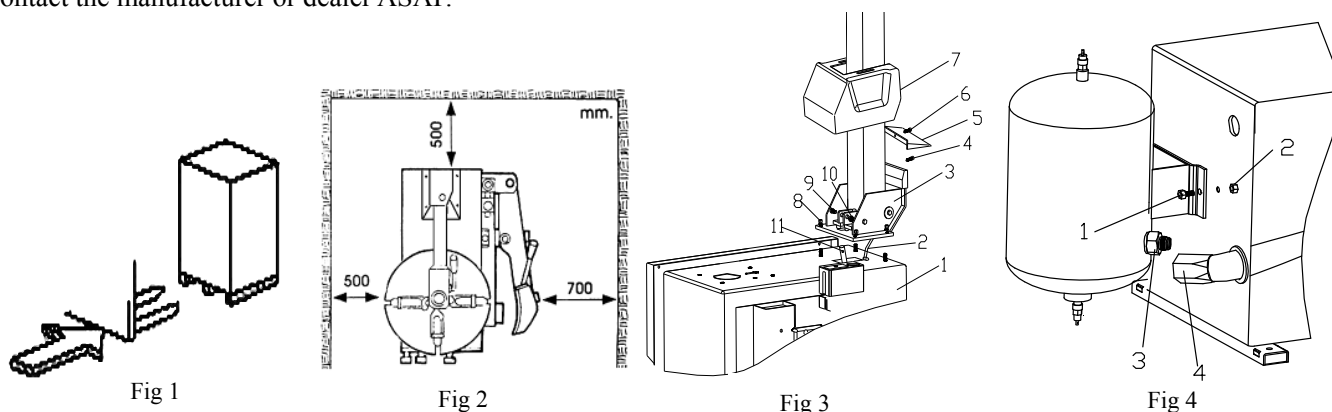

6. Workplace requirements:

Choose workplace in compliance with safety regulations. Connect power supply and air source according to manual and workplace must have good air condition; in order to make the machine run well, its workplace requires at least clear space from each wall shown as **Fig 2**. If installing it outdoor, it must be protected by roof against rain and sunshine.

Warning: the machine with motor must not be operated in explosive atmosphere.

7. Position and installation:

7.1 Install the column (accessories details refer to the exploded drawing)

- 1) Tools preparation
- 2) Place the tilting seat (3, Fig 3) on the body (1, Fig 3) with 4 bolts (M12), push air hose (2, Fig 3) through the hole of the column. Tighten 4 self-locking nut(8, Fig 3).
- 3) Insert screw (9, Fig 3) into the holes of both column and tilting cylinder shaft (11, Fig 3), tighten it with self-locking nut (10, Fig 3).
- 4) Unscrew the two bolts on the left cover and remove the cover, connect air hose (2, Fig 3) previously mentioned to the side holes which control the tilting 5-way valve. Fix the left cover.
- 5) Fix the plastic cover (7, Fig 3) with two bolts (4, Fig 3).
- 6) Mount the plastic back cover (5, Fig 3) on the column with screw (6, Fig 3).

7.2 Install the air tank assembly

- 1) Unscrew the left cover, fix air tank with machine body by bolt(1) and nut(2)
- 2) Fix metal pipe (4) with connector (3), make sure there is no air leakage, shown as Fig 4.

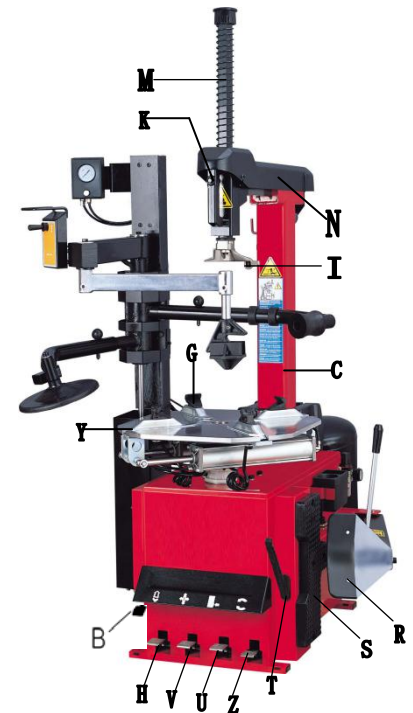

Fig E

8. Electricity and Pneumatic connections:

Warning: Before installation and connection, check to be sure that the electricity power supply corresponds to the machine technical data. All the installation of electric and pneumatic devices must be operated by a professional electrician.

Connect the compressed air connector which is on the machine right side with compressed air system. The electric grid that the machine connects to must have fuses protection device and good outer cover grounding protection. Install the leakage automatic air switch on the main power supply, leakage current is set at 30A

Caution: No power plug for this machine, the user should self-connect one power plug no less than 16A as well as in line with the machine voltage. Or directly connect with the power supply according to the above requirements.

9. Adjusting operation:



Tilting pedal (H)



Turntable Rotation pedal (Z)

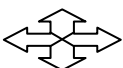

Jaws open and close pedal(V)

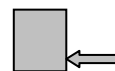

Bead Breaker pedal(U)



Rapid Tire Inflation Pedal (B)

Please note: below operation refer to **Fig E**

Tread the Turntable Rotation Pedal (Z), Turntable (Y) clockwise rotation;

Lift up the Turntable Rotation Pedal (Z), Turntable (Y) counterclockwise rotation.

Tread Bead Breaker Pedal (U), Bead Breaker shovel (R) compress; release Bead Breaker Pedal (U), Bead Breaker shovel (R) back to original position.

Tread totally down Jaws open and close Pedal (V), four clamps (G) on the turntable open; Tread again, four clamps (G) close. When the pedal is in the middle position, the four clamps stop moving.

Depress pneumatic locking button (K) to lock the Slide arm (N) and Vertical arm (M).

Tread the Bead Breaker pedal (H), the tilting column (C) backwards down; depress again, the tilting column return.

Tyre changer operation is consisted of three parts:

- 1) Demounting the tyre bead
- 2) Demounting the tyre
- 3) Mounting the tyre

Caution: Before any operations, don't wear loose clothing and wear protective hat, gloves, and skid-proof shoes. Ensure to exhaust the air in the tyre completely, and remove all the wheel weights from the rim.

9.1. Breaking the tyre bead:

Ensure to exhaust the air in the tyre completely, place the tyre against the rubber buffer (S). Bring the shovel (F) against the bead about 10mm from the edge of the rim shown as **Fig 5**. Depress Bead breaker Pedal (U) to push paddle into tyre. Repeat the above operations on different positions around the tyre and both sides of tyre until tyre bead is released completely.

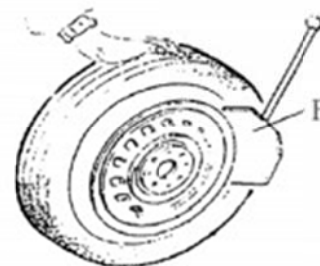

5

9.2. Demounting the tyre :

Ensure to remove all the weights on the wheel rim and to exhaust the air in the tyre completely before this operation. Apply lubricating grease (or similar lubricant) around the tyre bead. Without the lubricant may lead to badly wear and tear on tyre.

Clamp the wheel methods shown as below regarded to the ruled dimension:

a- to clamp the wheel from outside:

Depress the Jaws open and close Pedal (V) halfway down to middle, positioning for the four clamps (G) by reference scale on the Turntable (Y); put the tyre on turntable, hold the rim, and depress the Jaws open and close Pedal (V) until the wheel is secured by the jaws.

b- to clamp the wheel from inside:

Positioning for the four clamps (G) and let them all closed. Put the tyre on the turntable and depress the Jaws open and close Pedal (V) to open the clamps thereby lock the wheel in place.

Caution: Check to make sure the wheel firmly secured by the four clamps before next step.

Lower the Vertical Arm (M) until the Mounting head/demounting head (I) rests next to the edge of the rim, flip pneumatic locking button (K) to lock the Vertical Arm (M) and Horizontal arm in position, and control the distance from Mounting head/demounting head to the edge of wheel rim about 2-3 mm. Insert the Lifting Lever (T) between the tyre bead and the front section of the mounting head/demounting head (I), and move the tyre above the mounting head/demounting head as shown as **Fig 6**.

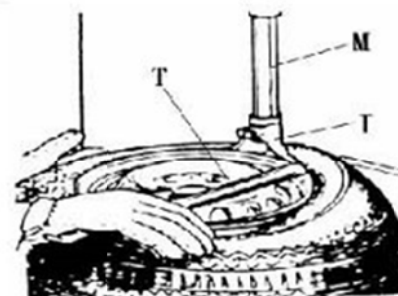

Caution: Chains, bracelets, loose clothes and anything else close to the rotating parts will bring danger to the operator.

With the Lifting Lever held in position, depress the Turntable Rotation Pedal (Z), rotate the Turntable (Y) in a

clockwise direction until the tyre is completely separated from the wheel rim.

For the other side tyre demounting, keep using the lifting lever to lift the tyre, make the other side tyre separated from the wheel rim. Depress the Tilting pedal (H), the column backward down, take out the tyre.

9.3. Mounting the tyre :

Caution: Check to make sure that the tyre and the wheel rim are of same size before mounting the tyre.

To avoid any damage on type, lubricate the tyre bead and the wheel rim with the lubrication recommended by manufacturer. Put on the tyre and check the situation.

Caution: When clamp the wheel rim, don't put your hands on the wheel rim to avoid injury during this operation.

Lock the Hexagonal Vertical Mounting Arm, put the tyre on the rim, let the Rocker Arm back to place as demounting the tyre. And let one side of tyre down bead above the rear section of the Mounting head/demounting head, the other side under the front section of the Mounting head/demounting head. Suppress the tyre with hands or help arm, and then spin the turntable for mounting the tyre down bead.

Repeat the above operation for mounting the tyre up bead. (Fig 7)



Fig 7

10. Help Arm 007B

The help arm 007B is an auxiliary device for tire changer, it is used to help to demount and mount tires.

Before any operation of this machine, the operator is requested to read the manual carefully. Do not attempt any operations that are not stated in it. Manufacturer will not be responsible for any injury or damage caused by improper operation. Please keep the manual handy for consulting.

10.1. Technical Data

Work Pressure	8~10 bar
Weight	110kg
Package dimension	1550*550*310mm
Noise Level	LpA<75db



10.2. Safety Regulations

This device is especially reserved to trained professional personnel or somebody who has experiences on mechanical operation and read this manual carefully. This device must be used together with our tire changers, we are not sure it can work with others. Manufacturer won't be responsible for any unauthorized modification

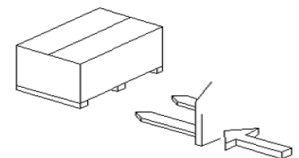

Fig 8

10.3. Installation

Notice!

The installation of this auxiliary device should be done by professional personnel. Before assembly, disconnect the device from power supply and air source.

10.3.1. Transport

Move the device with a forklift truck as illustrated in Fig 8.

10.3.2. Unpacking

When unpacking, check and make sure all parts shown on the packing list are included. If any parts are missing or broken, please call the manufacturer or the dealer asap. Please keep the package out of children's reach.

10.3.3. Workplace Requirement

Fig 9 shows the minimum distance (cm) from walls after assembly this auxiliary device. Please choose the right place to install it. And note keep at least 500mm from all direction for operation.

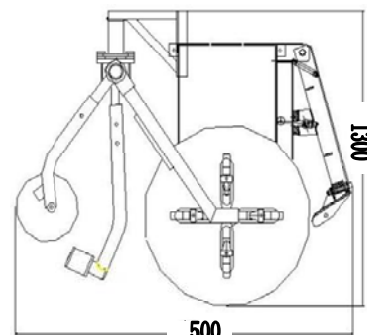

Fig 9

10.3.4 Assembly

Please install the the 007B help arm on the machine body as following steps:

- 1) Disconnect the tire changer from power supply and air source.
- 2) Remove the left cover of the body from the tire changer;
- 3) Install the upper support and bottom support on the help arm; Install the help arm on the tire changer with screw 1 and washer 2;(Fig 10)
 - 1、screw M10x 30
 - 2、washer ϕ 10
- 4) Install the tire pressing rotating arm 1, tire pressing head(upper) 2, rise-fall switch handle 3, tire lifting roller 4, tire pressing head(bottom) 5, tire pressing roller 6, tire pressing arm 8 separately on the help arm.(Fig 11)
- 5) Connect the air hose ϕ 6mm to the corresponding T-join through the rear hole of the body.
- 6) fix the left cover of the body back.

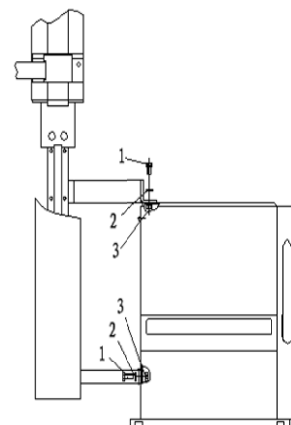

Fig 10

10.4. Functional Parts

Fig 11 shows functional parts of the 007B device:

- 1-tire pressing rotating arm
- 2-tire pressing head (upper)
- 3-rise-fall switch handle
- 4-tire lifting roller
- 5-tire pressing head (bottom)
- 6-tire pressing roller
- 8-tire pressing arm

The specifications for switch handle of help arm 007B:

The rise-fall switch handle (3, **Fig 11**) is to adjust the tire pressing rotating arm (1, **Fig 11**) when mounting and demounting tires.

10.5. Trial operation

The 007B device must connect with the air compressor, and the air pressure from 8 bar to 10 bar is desirable.

1) Lift the rise-fall switch handle(3, **Fig 11**) up, the tire pressing rotating arm (1, **Fig 11**) should rise. Down the rise-fall switch handle (3, **Fig 11**), the tire pressing rotating arm (1, **Fig 11**) should lower.

2) Bring the tire pressing rotating arm 1 to the center of the turntable, adjust the tire pressing rotating arm 1 by the rise-fall switch handle 3 to fix the tire with the tire pressing head (low) 5.

3) Operate the rise-fall switch handle (3, **Fig 11**) to adjust the tire pressing roller (6, **Fig 11**), make it get touch with the tire's arc to facilitate the mounting and demounting operations.

Safety warning label:

Warning: Unreadable and missing warning labels must be replaced immediately.

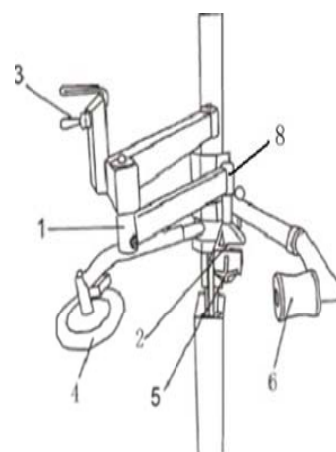

Fig 11



Do not use the tire changer if one or more labels are missing.

Do not add any object that could prevent the operator from seeing the labels.

Order the warning labels shown as below on the place where you need.

10.6. Operations

Mounting and demounting big flat tire is difficult work. By the help of 007B help arm to mount/demount the tire from the tire bead will make the operation easier. It is a good helper for tire changer.

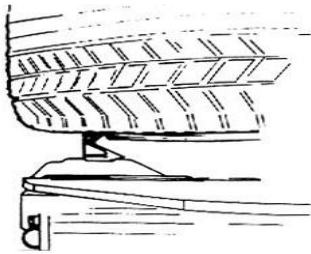

Fig 12

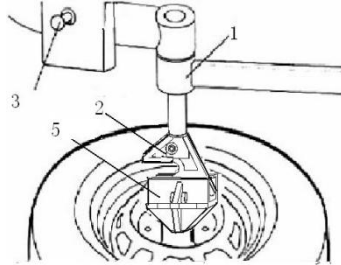

Fig 13

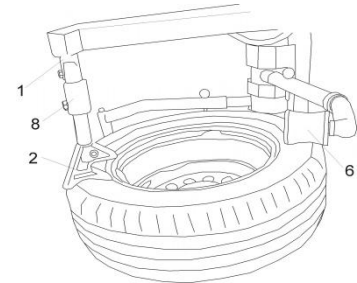

Fig 14

10.6.1. Fixing The Tire (function of central positioning)

- 1) Lubricate the bead according to the manual. Clamp the tire from outside (suggest to using the protection cover on the jaws)
- 2) Tread the corresponding pedal to open the jaws, and rotate the auxiliary arm to the non-working position;
- 3) Put the tire on the turntable, depress the corresponding pedal to close the jaws until they near the rim and touch with the tire.(Fig 12)
- 4) Insert the tire pressing head (upper) 2 and tire pressing head (bottom) 5 on the rotating arm 1;
- 5) Turn the rotating arm 1 to its working position. Fix the tire with the tire pressing head (upper) 2 and tire pressing head (bottom) 5 preparing for central positioning; (Fig 13)
- 6) Lower the auxiliary arm slowly with the switch handle 3 until the tire pressing head (bottom) 5 get touch with the rim center. Then lower it about 1 cm once more to make the jaws touch the rim;
- 7) Tighten the jaws, and raise the auxiliary arm with the switch handle. Remove the tire pressing head (upper) 2 and tire pressing head (bottom) 5, turn the rotating arm 1 to its non-working position.

10.6.2. Demounting The Tire

- 1). Loosen the beads with the tire pressing roller 6 again and again if necessary.

a- Adjust the tire pressing roller (6) according to the tire dimension; (note: no touch on the tire rim)

b- Down the switch handle 3 to lower the auxiliary arm, loosen the bead with the tire pressing roller 6. If need, change other positions to loosen ;(6, Fig 14)

Notice: Lubricate the bead before your operation.

c- Raise the auxiliary arm after loosening, and push the rotating arm 1 to non-working position. Get preparation for demounting.

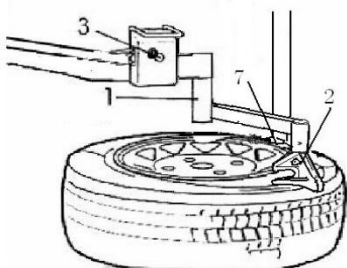

Fig 15

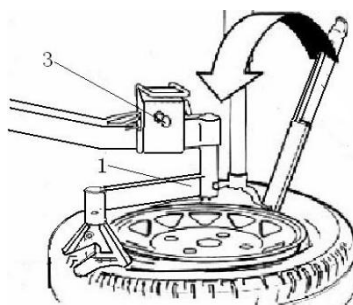

Fig 16

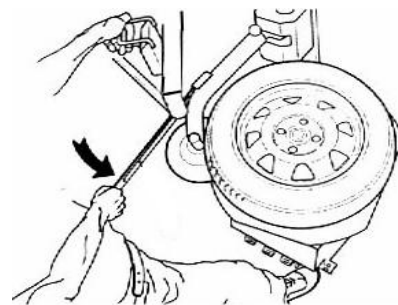

Fig 17

2). Demounting the upper bead

- a- Close the demount/mount head (7, Fig15) near from the tire as the manual stated. Move the rotating arm (1, Fig 15) to its working position.
- b- Move the tire pressing head (upper) (2, **Fig 15**) near from the demount/mount head, down the rise-fall switch handle to press the bead with the tire pressing head (upper) so as to place the demount/mount head. Insert the lifting lever according to the instruction of tire changer;
- c- Raise the auxiliary arm, mount the tire pressing head (upper) on the tire pressing arm (8 Fig 11) and rotate it to the opposite side of the mounting head. Press the tire with the switch handle to create enough space; hang the bead on the demount/mount head with the help of the lifting lever(Fig.16).
- d- Raise the auxiliary arm and push it to non-working position;
- e- Depress the corresponding pedal to turn the turntable in clockwise direction, and then the upper bead will be removed from the tire.

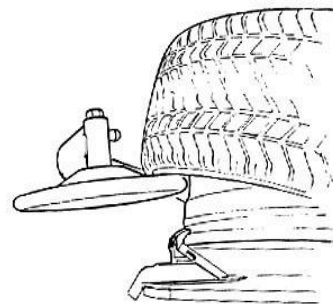

Fig 18

3). Loosening the bottom bead

- a- Bring the rotating arm to non-working position;
- b- Position the tire lifting roller under the tire, make sure it is near the edge of the rim but not touch it;
- c- Insert the lifting lever to the special hole and hold it to keep the tire lifting roller pressed against the tire;
- d- Depress the corresponding pedal to turn the turntable in clockwise direction, operate the switch handle to rise the auxiliary arm until the bottom bead remove from the rim completely; (Fig 17)

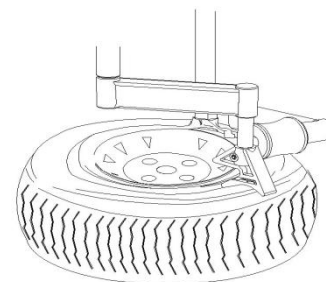

Fig 19

4). Demounting the bottom bead

Note: With some tires, the bottom bead can be removed only by the tire lifting roller. To do this, continue the bead loosening procedure until the bead detach from the rim completely.

The tire lifting roller always facilitates the bead demounting especially for sports tires with wide tread.

- a- Position the tire lifting roller and lift the bottom bead until it is in the drop center; (Fig 18)
- b- Hang the bottom bead on the mounting head using the lifting lever;
- c- Remove the tire lifting roller and depress the corresponding pedal to turn the turntable in clockwise direction until the bottom bead detach from the rim completely.

10.6.3. Mounting the tire

- 1) Mount the bottom bead on the rim as the instruction of tire changer.

Warning! Move the rotating arm to non-working position before operation so as to avoid the danger caused by collision!

- 2) Rotate the roller support to move the tire pressing roller near the mounting head (about 3-4 cm). Position the tire pressing head (upper) about 90 degree with the mounting head. Lower the auxiliary arm to press the tire below the mounting head 3-5 mm with the tire pressing roller. Tread the corresponding pedal to turn the turntable in clockwise direction. Then the tire pressing head (upper) rotate together with the turntable to mount the tire.(Fig 19)

Note: Pay special attention to this procedure. Make sure the tire pressing head (upper) and tire pressing roller don't touch the rim. Or it will cause damage to the rim caused by friction.

11. Inflating the tire :

Importance: It is very dangerous during inflating operation, take carefully and comply with instruction. When inflating, it will turn to be extremely dangerous if problems happen to tyre or rim. The possible burst force tire goes upward and outward, the big power may cause injury or death of the operator or the people around.

Tyre may burst caused by following:

- 1) The wheel rim and the tyre are not of the same size;
- 2) The tyre or the wheel rim is damaged;
- 3) The pressure of tyre inflation is over the max. pressure recommended by manufacturer;
- 4) The operator fails to comply with the safety regulation;

Please operate as follows:

- 1) Remove the valve cap from the valve stem;
- 2) Check to make sure the air nozzle is pressed down completely over the threads of the valve stem.
- 3) Check to make sure that the tyre and the wheel rim are of the same size;
- 4) Lubricate both the tyre bead and the wheel rim, additional lubrication is required if needed;
- 5) Inflate the tyre with break, while inflating, check the pressure listed on the pressure gauge, also check whether the bead is fixed or not. Repeat operation above until the bead is secured; you need take special steps when inflating convex rim or double convex rim;
- 6) Continue inflating and check the air pressure frequently until to reach the required pressure.

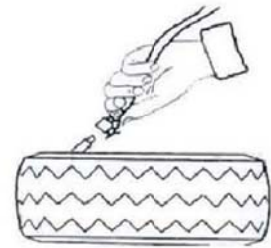

Fig 20

Note: Never exceed the max. inflation pressure given by the tyre manufacturer.

Keep hands and your body away from inflating tyres.

Only specially trained persons are allowed to perform the operations, do not allow other to operate or be near the tyre changer.

12. Moving machine:

Please use forklift to move the machine. Disconnect the tyre changer from the electricity power supply and pneumatic power supply, lift the base board and insert the feet of forklift. Then mount the tyre changer machine to a new position and fix it tightly.

Note: the place chosen for fixing the tyre changer must meet the safety regulation.

13. Maintenance:

Caution: only the professional persons can do the maintenance. To prolong the machine's life, maintain the machine timely according to the manual. Otherwise, it will impact the reliability of the machine or even cause injury to operator and others nearby.

Caution: before performing any maintenance, disconnect the tyre changer from the electric power supply and pneumatic power supply, and tread the Jaws open and close Pedal or Turntable Rotation Pedal for 3~4 times to evacuate all compressed air from the machine. Damaged parts must be replaced by professional persons with the spare parts provided by manufacturer.

Fig 21

- Clean the machine once every day after work. Clean the dirt on the turntable with diesel oil once per week and lubricate the slides and clamps.

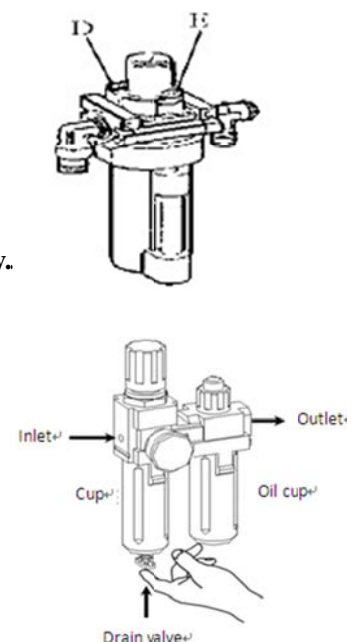

Fig21-1

- Following maintenance must be done at least once per month:
Check oil level in Oil Fog Maker, please be filled with SAE30# oil if need.
Unscrew with hex wrench (E). Based on connection of compressed air, first to tread Jaws open and close Pedal or Turntable Rotation Pedal 5-6 times, and then check whether oil in Oil Fog Maker drops down a drip of oil. For continuous operation, tread twice every time, drop down a drip of oil, otherwise adjust the screw (D) that controlled oil enter with minus screwdriver.

(Fig 21)

- As shown in Figure 21-1, when you found there are some water in the cup, push up the drain valve to drain away water with your fingers; loosen your fingers after drained water, drain valve can be automatic closed under the action of the spring.

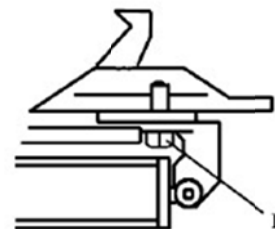

Fig 22

Note: After the first 20 days of use, retighten the jaws with tightening screws (B) on the Turntable (Fig 22)

Note: in the event of turntable lose power, check to see if the belt is tight as follow steps:

Remove the left side cover by unscrewing the screws; adjust two screws located on the motor support, keep a suitable distance between motor support and motor base; tight the screws for the belt tension.(Fig 23)

Caution: please disconnect the machine from electric power supply and pneumatic power supply.

Note: If Vertical Arm not be locked or not meet the requirement that 2-3mm from the bottom of Mounting head/demounting head to rim, please adjust Hexagonal Locking Plate, refer to Fig 24 and adjust the (X).

Note: In order to achieve the reliability of jaws and Bead Breaker shovel, operate as follows to keep their valves clean:

1. Remove the left side cover of the machine body by unscrewing the two screws;
2. Loosen the valve mufflers (A) which belong to Jaws open and close Pedal and Bead Breaker Pedal; (Fig 25)
3. Clean the mufflers with compressed air, please replace it referring to the spare parts list if it is damaged. (Fig 25)

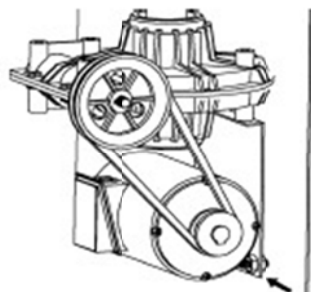

Fig 23

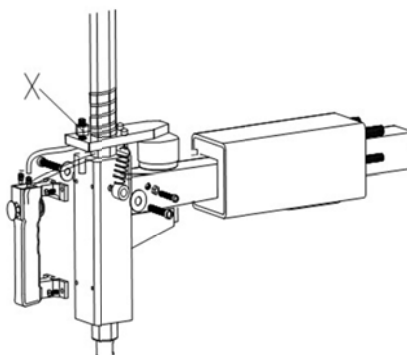
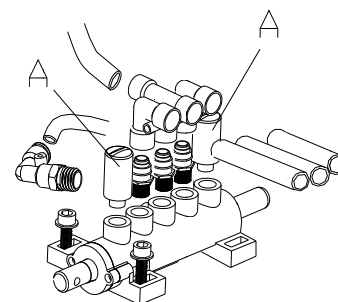

Fig 24



5

14. Rapid tyre inflation system (only suitable for the IT-suffix version machine):

14.1. Rapid Tire Inflation Device:

Note: before inflating operation, please make sure the pneumatic power supply connect well.

Before operation, must check the devices perform well as follow:

- a. Press Rapid Tire Inflation Pedal to the middle position (Fig 26, position 1), the inflating head should give air.
- b. Press Rapid Tire Inflation Pedal all the way down (Fig 26, position 2), a strong air blast should come from the holes in the four jaws' locking sliders. (Fig 27)

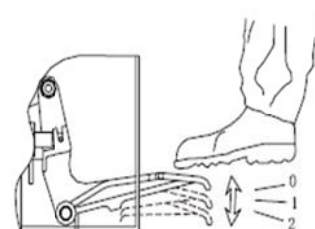

Fig 26

14.2. Wheel rim lock and Tire inflation:

Note: A wheel can explode if:

- 1). the diameter of the rim is not exactly the same as the tyre's.
- 2). the rim or tyre are defective.
- 3). the tyre is inflated to a pressure higher than the maximum recommended by the manufacturer.
- 4). the operator does not observe the requisite safety regulations.

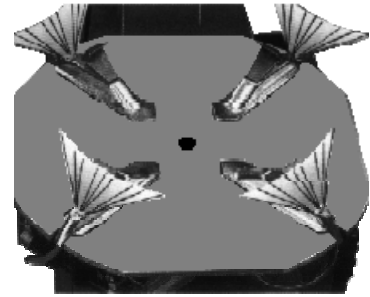

Fig 27

14.3. Inflation for tire with inner tube:

- 1). Remove the valve stem.
- 2). Check to be certain that tyre and rim diameter correspond.
- 3). Check to be certain that rim and beads are sufficiently lubricated.
- 4). Press the pedal down to the middle position to start inflation.
- 5). Release frequently the inflating pedal to check pressure on the manometer. If the air pressure is too high, press the button under the manometer for release the rest air until the correct pressure is reached.

14.4. Inflation for tubeless tire:

Note: When inflating tubeless tire using a strong jet of air, the wheel must be clamped from the inside of the rim.

- 1). Remove the valve stem.
- 2). Check to be certain that tire and rim diameter correspond.
- 3). Check to be certain that rim and beads are sufficiently lubricated.
- 4). Press the pedal down to the middle position to start inflation.
- 5). If the bead of the tyre is not well seated, due to a strong bead, lift tyre manually until the upper bead seals against the rim, then press the pedal all the way down. A strong jet of air will be released through the nozzles in the slides and this will help the bead seal.
- 6). Release the tyre, set the pedal back to the middle position and continue to inflate the tyre to the required pressure. If the air pressure is too high, press the button under the manometer for release the rest air until the correct pressure is reached.

Note:

- 1). **Failure to follow all warnings and instructions may lead to serious personal injury or death to operator or bystander. NEVER exceed 3.5 bar (50 psi) when seating beads or inflating tyres.**
- 2). **If a higher tire inflation pressure is required, remove the wheel from the tyre changer and continue the inflation procedure with the wheel inside a special protection cage. NEVER exceed the maximum inflation pressure given by the tyre manufacturer.**
- 3). **Only specially trained persons are allowed to perform these operations. Do not allow others to operate or be near to the tyre changer.**

15. Trouble shooting table:

Problem	Reason	Solution
The turntable rotate just in one direction or can't rotate.	Reverse Switch broken	Replace the Reverse Switch
	Belt broken	Replace the belt
	The Motor's malfunction	Check the motor cable or terminal block wire; Replace the motor if it was broken.
Demount or fix the wheel, the turntable can't lock (spin with wheel); The jaws delay to open/close; The turntable locks the rim incorrectly.	Leakage of Air network	Check all the parts on the air network.
	The clamping cylinder can't work.	Replace the cylinder piston.
	Worn jaws	Replace the jaws.
	Broken washers of the chuck cylinder	Replace it.
The mounting head/demounting head always touch the rim during operation.	The locking plate incorrectly adjust or unqualified.	Replace or adjust it.
	Screws on the chuck loose; the Vertical Arm can't be locked by Locking Plate	Tighten the screws; replace the Locking Plate.
The Bead Breaker Pedal and Jaw open and close Pedal can't turn back to the original position.	pedal spring broken	Replace it.
The Bead Breaker shovel operates difficultly.	Jammed silencer	Clean it or replace it.
	The washer on the Bead Breaker cylinder is broken.	Replace it.

16. Guide for ordering spare parts

1. Firstly, the damaged or ordered sample should be gained and confirmed the quantity of spare parts
2. Confirm the replaced parts specification, avoid wrong order.

The confirmed method showed as following:

According to the use range and place position of parts, find out the codes of parts in the exploded drawing (section 17) from the manual.

For example, if lifting level is needed to be ordered, resulting from the fact that lifting level always placed in the sleeve, and its exploded drawing position is showed as below:

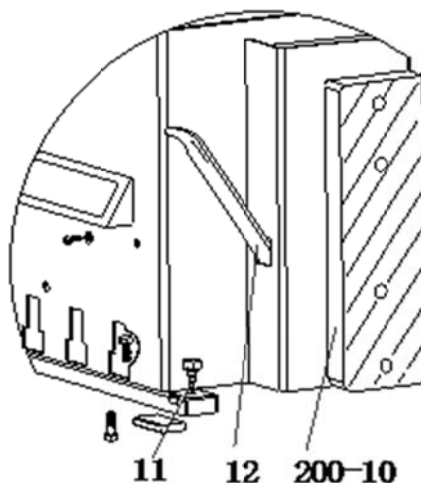

We can see the code “12” from the picture, then find out all the information of code “12” and record them.

11	B-027-060401-0	Grounding screw M6x40
12	C-200-580000-0	Lifting level
200-10	C-200-500000-0	Bead breaker rubber

The recorded information:

12	C-200-580000-0	Lifting level
----	----------------	---------------

3. Gather the detailed information of parts

Code .	Order code	Name	Qty	Purchase time of machine
12	C-200-580000-0	Lifting level	2	2009. 6. 25

4. Please contact the spare parts department and confirm the order.

5. After confirming the order with any problem, the spare parts department will deliver the goods for you according to the order.

Special statement

◆Manufacturer reserves the rights to change the parts specification without beforehand notice for the users.

◆Manufacturer do not liable for the modification and improvement of the products which have been sale

17. Wearing spare parts list

Query NO.	Order NO.	Parts name	Query NO.	Order NO.	Parts name
221-10	C-221-500000-0	Bead breaker buffer	200-321	S-000-175500-0	O- seal 0173.4×5.3
226	S-005-020075-0	V- seal 20*28*7.5	331	S-000-019262-0	O- seal 0 19.6*2.62
227	S-000-063265-0	O- seal 63*2.65	200-426	S-060-016000-1	Reverse switch
200-228	C-200-540000-0	clamp cylinder piston 070	521	S-000-030355-0	O- seal 0 30*3.55
232	S-000-019262-0	O- seal 019.6×2.62	200-522	C-200-320700-0	Oil seal resistance
306	S-000-016265-0	O- seal 0 16*2.65	200-532	S-000-059262-0	O- seal 59.9*2.62
307	S-000-020265-0	O- seal 0 20*2.65	604	S-042-000686-0	Tyre changer belt A-28
200-308	S-000-180500-0	O- seal 180×5	A86	S-030-010400-0	Drain valve
311	S-005-168115-0	V- seal 185×168×10.8			
12	C-200-580000-0	Lifting lever	801	S-033-200002-1	Decompression filter
300-139	C-300-150000-0	Mount/demount head 7#	804	S-033-200002-2	Oil fog maker
200-204	C-200-570000-0	Jaw 200	200-370	C-200-070600-0	Tyre pressing shovel protector (optional)

Remark : The parts in the list are easy broken parts, if other parts needed to be ordered, please check the manual.

18. Exploded drawing:

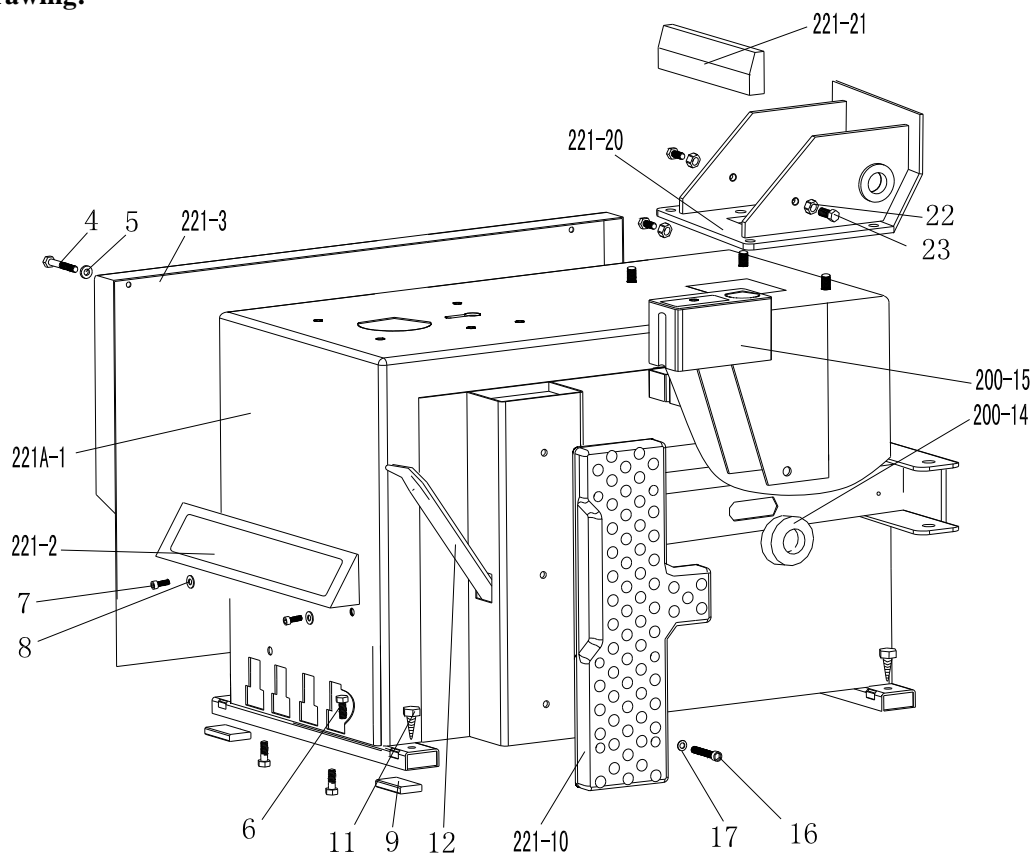

221A-1	CX-221-010000-A	Machine body 221
221-2	CX-221-080000-0	Pedal front cover
221-3	CX-221-020000-A	Left cover
4	B-010-060101-0	Hex socket head bolt M6×10
5	B-040-061412-1	Flat washer Ø6*14*1.2
6	B-014-080251-0	Outer hex bolt M8x25
7	B-014-08201-0	Hex socket head bolt M8×20
8	B-040-082220-1	Flat washer Ø 8*22*2
9	C-000-001020-0	Rubber foot buffer
221-10	C-200-500000-0	Bead breaker buffer
11	B-027-060401-0	Grounding screw M6x40
12	C-200-580000-0	Lifting lever
200-14	C-200-510000-0	Bead breaker arm rubber
200-15	C-200-470000-0	Oil-water box
16	B-010-080201-0	Hex socket head bolt M8x20
17	B-040-081715-0	Flat washer Ø8*17*1.5
221-20	CX-221-010106-0	Tilting seat
221-21	C-221-820000-0	Tilting protect cover
22	B-001-100001-0	Self-locking nut M10
23	B-014-100251-0	Outer hex bolt M10*25

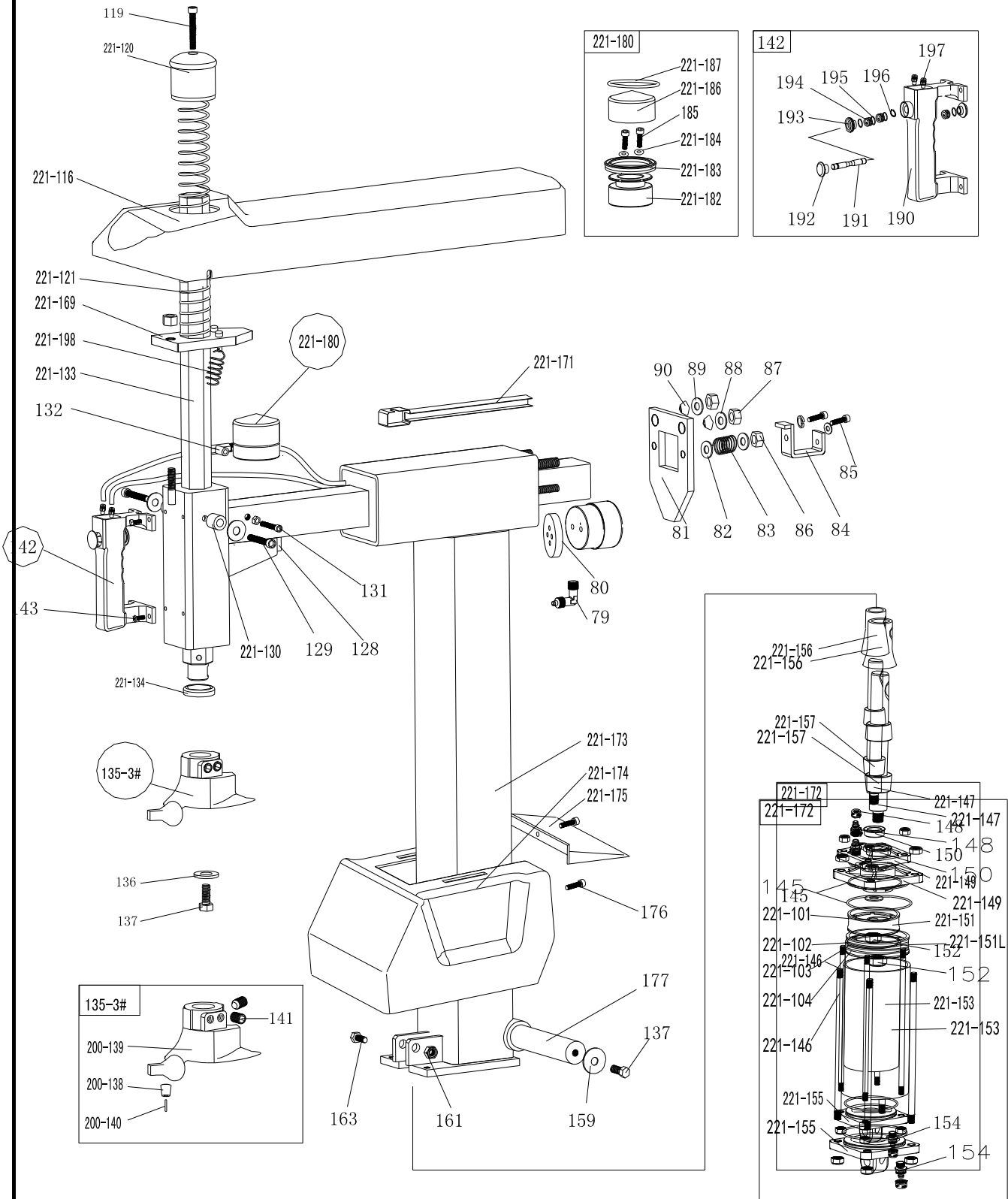

79	S-012-010806-0	Quick union 1/8-Ø6	221-149	C-221-350100-0	Tilting cylinder cover without handle
80	C-221-250600-0	Locking cylinder plate	150	S-005-020075-0	V seal Ø20*28*7.5
81	CX-221-190000-0	Horizontal arm locking plate	221-151L	C-221-550000-L	Tilting cylinder piston(Al-alloy) φ 75
82	B-040-081715-1	Flat washer Ø8*17*1.5	152	B-004-120071-0	Nut (silver) M12*1.5*7
83	C-221-410000-0	Horizontal arm locking spring	221-153	C-221-350500-0	Tilting cylinder barrel
84	CX-221-240000-0	Horizontal arm block	154	S-010-010806-0	Straight union 1/8-Ø6
85	B-014-080201-0	Outer hex bolt M8*20	221-155	C-221-350300-0	Tilting cylinder cover with handle
86	B-001-080001-0	Self-locking nut M8	221-156	CX-221-351000-0	Tilting cylinder piston rod cover
87	B-001-120001-0	Self-locking nut M12	221-157	C-221-350700-0	Tilting cylinder rubber sheath 1
88	B-040-122520-1	Flat washer Φ 12*25*2	137	B-014-100251-0	Outer hex bolt M10×25
89	B-040-122520-1	Flat washer Φ 12*25*2	159	B-040-104030-1	Flat washer 10*40*3
90	C-221-230000-0	Locking spacer	161	B-001-120001-0	Self-locking nut M12
221-116	C-221-480000-0	Horizontal arm protection back cover	163	B-014-120651-0	Outer hex bolt M12×65
119	B-010-100501-0	Hex socket head bolt M10*50	221-169	CX-221-220000-0	Hex locking board 221
221-120	C-228-490000-0	Vertical arm cap 228	221-171	C-221-790000-0	Hose guide
221-121	C-228-390000-0	Vertical arm spring	221-172	CW-105-021102-0	Complete tilting cylinder
127	B-007-120161-0	Hex socket head bolt M12*16	221-173	CX-221-250000-A	Column
128	C-221-200000-0	Shock absorber	221-174	C-231-450000-0	Column protection cover
129	B-010-060351-0	Hex socket head bolt M6×35	221-175	C-221-460000-0	Tilting Column back cover
221-130	P-120-260000-0	Guide pulley	176	B-024-050161-1	Cross head screw 5*16
131	B-010-060161-0	Hex socket head bolt M6×16	177	CX-221-260000-0	Column shaft
132	S-017-010806-2	T-union 1/8-2*Ø6	221-180		Complete locking cylinder
221-133	CX-221-160000-0	Vertical arm	221-182	C-221-090100-0	Complete locking cylinder piston
221-134	C-228-520000-0	Vertical arm washer	221-183	S-005-050065-1	V seal 50*60*6.5
136	CX-200-170000-0	Mount/demount head flat washer	221-184	S-000-006300-0	O seal 6*3
137	B-014-100251-0	Outer hex bolt M10×25	185	B-010-060551-0	Hex socket head bolt M6×55
300-123	C-2592-150500-0	Mount/demount head flat protector	221-186	CX-221-090200-0	Locking cylinder cover Ø60
200-124	C-200-150400-0	Hex round pin	221-187	S-000-052200-0	O seal 52×2
292-125	C-2592-150300-0	Mount/demount head protector	190	C-221-210100-0	Pneumatic handle switch plate
135-7#	CW-113-030000-0	Complete Mount/demount head 7#	191	C-221-210200-0	Pneumatic handle valve rod
300-139	C-300-150000-0	Mount/demount head 7#	192	C-221-210500-0	Pneumatic valve rod cap
141	B-007-120161-0	Hex socket head bolt M12X16	193	C-221-210300-0	Pneumatic handle cover
142	CW-119-021100-0	Complete Pneumatic locking switch	194	C-221-210400-0	Pneumatic handle spacer
143	B-010-060161-0	Hex socket head bolt M6*16	195	S-000-007265-0	O seal 7.5*2.65
145	S-000-068353-0	O seal Ø68.26*3.53	196	B-055-080001-0	Snap ring Ø8
221-146	C-221-350900-0	Tilting cylinder threaded	197	S-010-010806-0	Straight union
221-147	C-221-350200-0	Tilting cylinder piston rod	221-198	C-221-400000-0	Hex locking board spring
148	B-001-080001-0	Self-locking nut M8	199	B-007-100121-0	Hex socket head bolt M10*12
221-101	S-000-011180-0	O seal φ11*1.8	221-103	S-000-068353-0	O seal φ68*3.53
221-102	S-005-065075-0	Y seal φ65*75*6	221-104	S-000-065053-0	O seal φ65*5.3

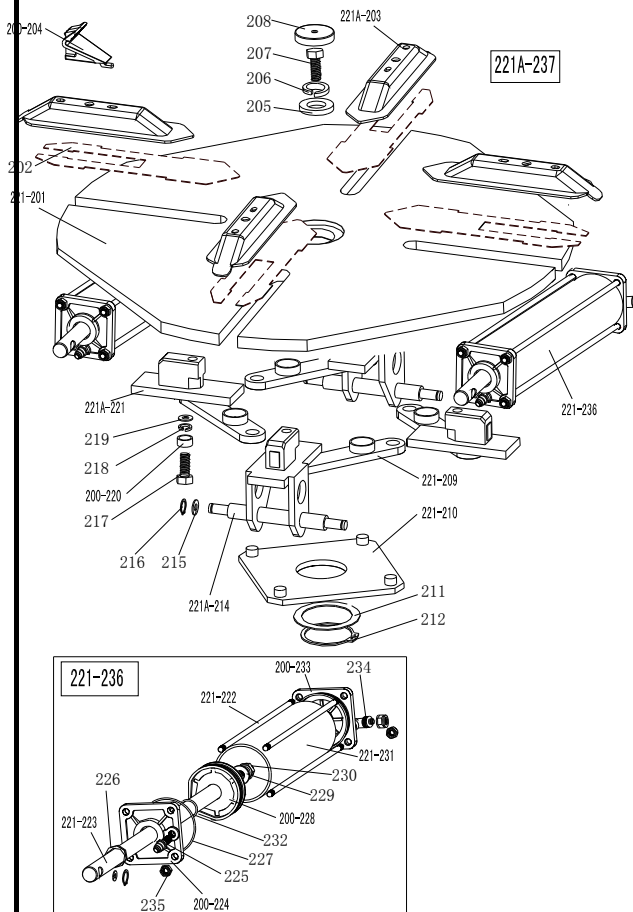

221-201	CX-221-130000-0	Turntable 615
202	CX-221-120300-0	Jaw sliding plate(optional)
221A-203	CX-221-120000-A	Jaw cap assembly
200-204	C-200-570000-0	Jaw 200
205	CX-200-140000-0	Big washer
206	B-050-160000-0	Spring washer Ø16
207	B-014-160401-0	Outer hex bolt M16×40
208	C-200-440000-0	Turntable cap
221-209	CX-221-310000-0	Connection rod assembly 615
221-210	CX-221-280000-0	Square turntable 615
211	CX-200-290000-0	Square turntable washer
212	B-055-650001-0	Snap ring Ø65(shaft)
221A-214	CX-221-110000-A	Jaw slide guide with pin 615A
215	B-040-122520-1	Flat washer Ø12X25X2
216	B-055-120001-0	Snap ring Ø12(shaft)
217	B-014-120801-0	Hex socket head bolt M12×80
218	B-046-122050-1	Teeth locking washer Ø12*1
221A-237	CW-104-021100-A	Complete square turntable 615A
219	B-040-123030-1	Flat washer Ø12X30X3
200-220	CX-200-300000-0	Connection rod nut
221A-221	CX-221-110100-A	Jaw slide guide without pin 615A
221-222	C-221-100400-0	Threaded connection rod 393
221-223	C-221-100200-0	Clamping cylinder piston rod 400
200-224	C-200-100100-0	Clamping cylinder cover without handle
225	S-011-010808-0	Straight union 1/8"-Ø8
226	S-005-020075-0	V- seal 20*28*7.5
227	S-000-063265-0	O- seal 63*2.65
200-228	C-200-540000-0	Clamping cylinder piston Ø70
229	B-040-122520-1	Flat washer Ø12X25X2
230	B-004-120071-1	Nut M12X7X1.75
221-231	C-221-100500-0	Clamping cylinder barrel 360
232	S-000-019262-0	O- seal Ø20X2.65
200-233	C-200-100300-0	Clamping cylinder cover with handle
234	S-018-010808-0	Quick union 1/8-Ø8
235	B-001-080001-0	Self-locking nut M8
221-236	CW-105-021100-0	Complete clamping cylinder

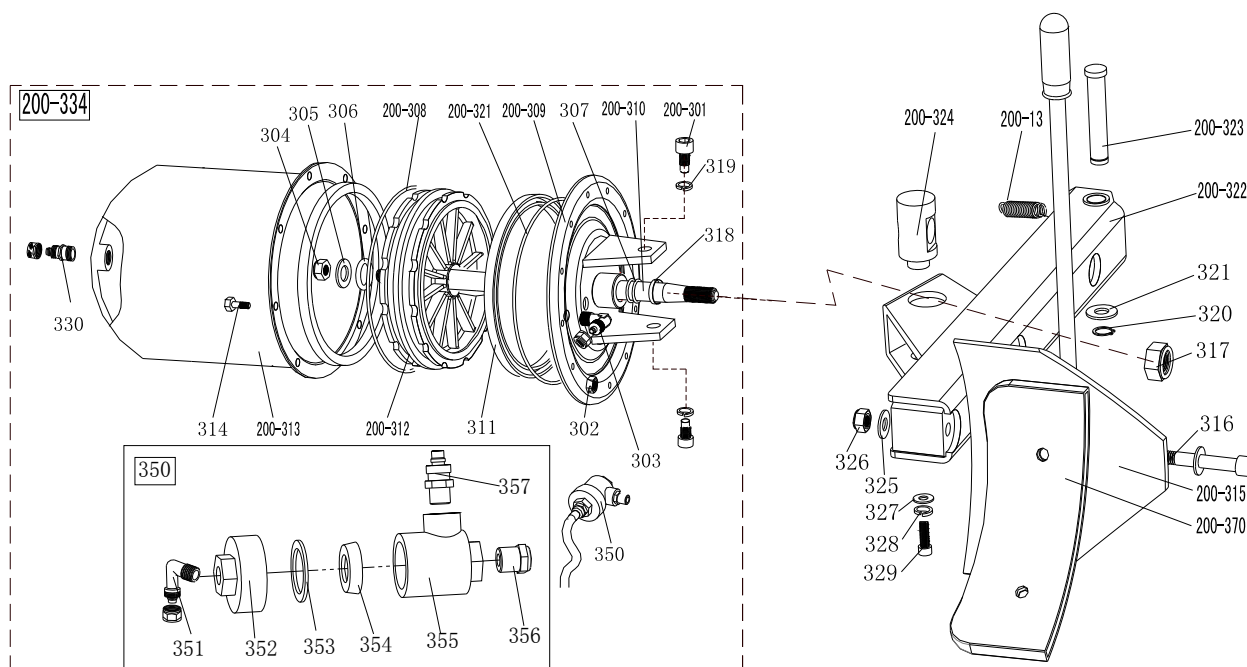

200-13	C-200-360000-0	Bead breaker arm spring	320	B-055-160001-0	Snap ring Ø16
200-301	B-010-140301-0	Hex socket head bolt M14×30	331	S-000-019262-0	O-ring Ø 19.6*2.62
302	B-001-060001-0	Self-locking nut M6	200-321	S-000-175500-0	O-seal Ø170.8x5.33
303	S-018-010408-0	Union (90°) 1/4-Ø8	200-322	CX-200-030000-0	Bead breaker arm 200
304	B-001-160001-1	Nut M16*1.5	200-323	CX-200-040000-0	Bead breaker pin
305	B-040-162820-1	Flat washer Ø16*28*2	200-324	CX-200-050600-0	Bead breaker cylinder rotating pin
306	S-000-016265-0	O-seal Ø 16*2.65	325	B-040-122520-1	Flat washer Ø12*24*2
307	S-000-020265-0	O-seal Ø 20*2.65	326	B-001-120001-0	Self-locking M12
200-308	S-000-180500-0	O-seal 180x5	327	B-040-083030-1	Flat washer Ø8*30*3
200-309	CX-200-050500-0	Bead breaker cylinder cover assembly	328	B-050-080000-0	Spring washer Ø8
200-310	C-200-050100-0	Bead breaker cylinder piston rod	329	B-014-080201-0	Outer hex bolt M8×20
311	S-005-168115-0	V-seal 185X168X10.8	330	S-011-010808-0	Straight union 1/8-Ø8
200-312	C-200-050200-0	Bead breaker cylinder piston	200-334	CW-108-020000-0	Complete bead breaker cylinder
200-313	CX-200-050300-0	Bead breaker cylinder barrel	350	CW-112-209800-0	Bead breaker cylinder exhaust valve
314	B-010-060161-0	Hex socket head bolt M6×16	351	S-012-010808-0	Union (90°) 1/8-Ø8
200-315	CX-200-070000-0	Bead breaker shovel assembly	352	C-098-600200-0	Bead breaker cylinder exhaust valve cover
316	B-010-120901-0	Hex socket head bolt M12×90	353	C-098-600400-0	Seal washer
317	B-001-160001-1	Self-locking nut M16*1.5	354	C-098-600300-0	Bidirectional seal
318	U-006-000001-1	Guide belt	355	C-098-600100-0	Bead breaker cylinder exhaust valve barrel
200-370	C-200-070600-0	Bead breaker shovel protection cover(optional)	356	S-023-010401-6	Muffler
319	B-050-140000-0	Spring washer Ø14	357	S-010-010408-0	Straight union 1/4- Ø8

231-480

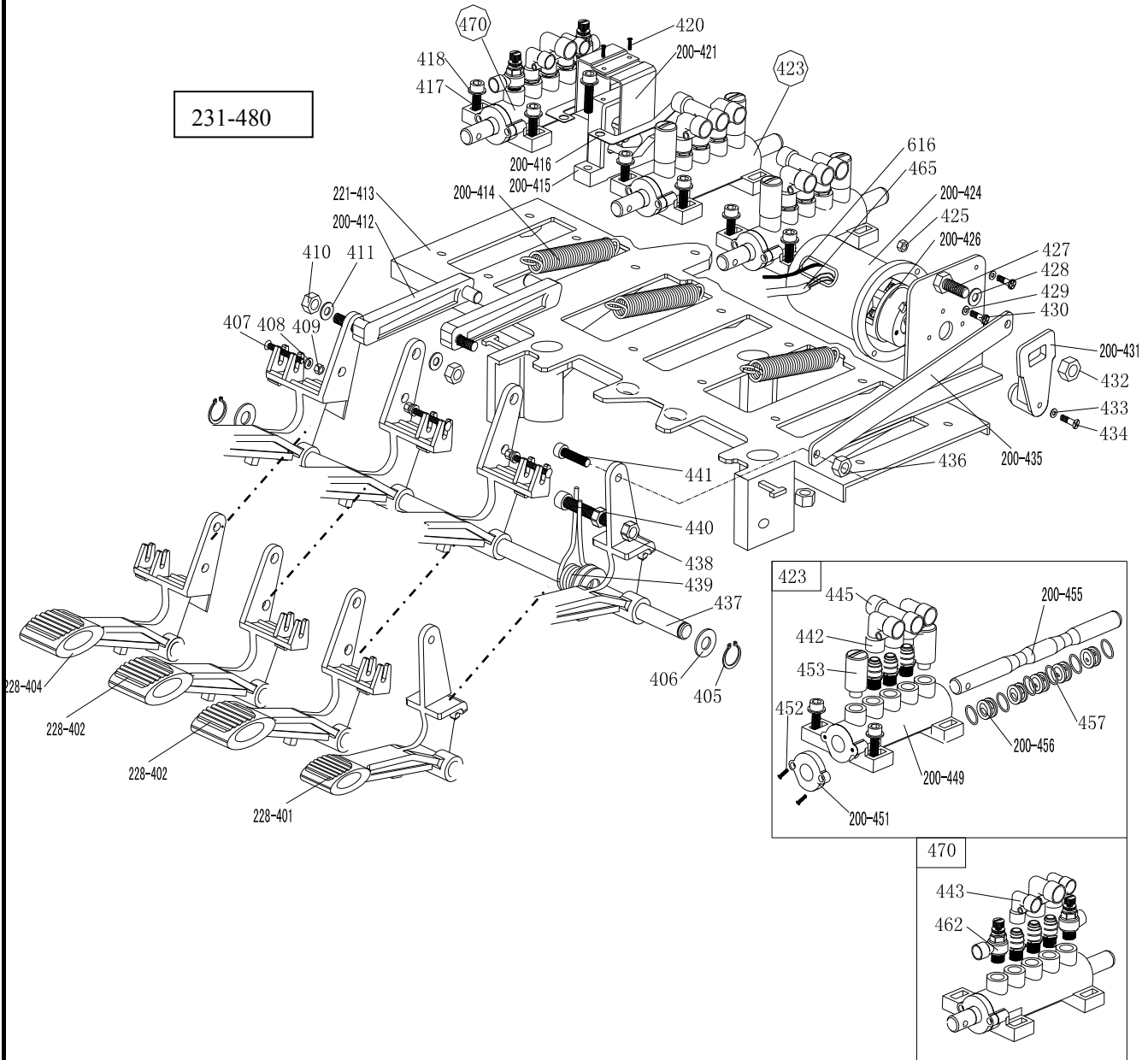

228-401	C-228-060400-0	Reverse switch pedal	429	B-040-040000-1	Flat washer Ø 4
228-402	C-228-060300-0	5-way valve pedal(right)	430	B-024-040161-0	Cross head screw M4*16
228-404	C-228-060200-0	5-way valve pedal(left)	200-431	C-200-530000-0	Reverse switch handle
405	B-055-120001-0	Snap ring Ø12	432	B-001-060001-0	Self-locking nut M6
406	B-040-122520-1	Flat washer Ø12*24*2	433	B-040-030000-1	Flat washer Ø3
407	B-017-040301-0	Cross head screw M4X30	434	B-017-030161-0	Cross head screw M3X18
408	B-040-040000-1	Flat washer Ø 4	200-435	CX-200-060600-0	Pedal connection rod
409	B-001-040001-0	Self-locking nut M4	436	B-001-080001-0	Self-locking nut M8
410	B-001-080001-0	Self-locking nut M8	437	CX-221-060700-0	Pedal front shaft
411	B-040-081715-1	Flat washer Ø8*17*1.5	438	B-004-080001-0	Nut M8
200-412	C-200-061300-0	Cam connection rod	439	C-200-370000-0	Pedal twist spring
221-413	C-221-060100-0	Pedal support board	440	B-010-080501-0	Hex socket head bolt M8×50
200-414	C-200-380000-0	Pedal Spring	441	B-010-080201-0	Hex socket head bolt M8×20
200-415	C-200-061500-0	Cam	442	S-012-010808-0	Quick union1/8- Ø 8
200-416	C-200-810000-0	Cam washer	443	S-012-010806-0	Quick union1/8- Ø 6
417	B-010-060201-0	Hex socket head bolt M6×20	445	S-016-010808-2	Quick T-union1/8-2* Ø 8
418	B-040-061210-1	Flat washer Ø6	200-449	C-200-060901-0	5-way valve barrel (right)
420	B-019-290121-0	Cross head self tapping screw 2.9*12	200-451	C-200-061100-0	5-way valve cover
200-421	CX-200-060500-0	Cam cover	452	B-024-290-121-0	Cross head ST2.9*14
423	CW-110-020001-0	Complete 5-way valve for Bead breaker cylinder	453	S-023-010801-0	Muffler 1/8"
200-424	C-200-061400-0	Reverse switch cover	200-455	CX-200-061200-0	5-way valve rod
425	B-004-040001-0	Nut M4	200-456	C-200-061000-0	5-way valve rod spacer
200-426	S-060-016000-1	Reverse switch	457	S-000-012400-0	O seal 12*20*4
427	B-010-060201-0	Hex socket head bolt M6×20	462	S-030-010806-0	Throttle valve
428	B-040-061210-1	Flat washer Ø 6X12X1	470	CW-110-021102-0	Complete tilting 5-way valve
231-480	CW-109-023100-0	Complete 4-pedals assembly 231			

300A-526

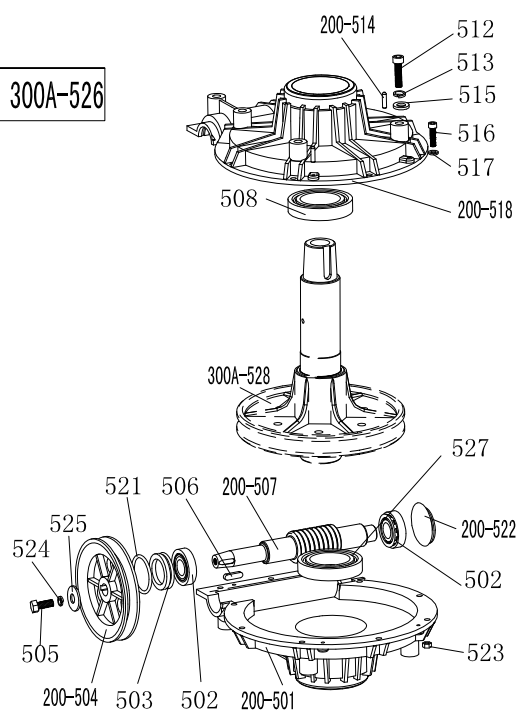

200-501	C-300-320302-0	Gear box lower cover
502	S-040-030204-0	Bearing 30204
503	S-005-020080-1	Gear box seal $\phi 20 \times 35 \times 8$
200-504	C-200-320500-0	Gear Belt pulley
505	B-014-080251-0	Outer hex bolt M8 \times 25
506	B-065-006020-0	Key washer 6 \times 20
200-507	C-200-320400-0	Worm rod
508	S-040-006010-0	Bearing 6010
512	B-014-100551-0	Outer hex bolt M10 \times 55
513	B-050-100000-0	Spring washer $\phi 10$
200-514	B-060-006020-0	Pin 6X20
515	B-040-102020-1	Flat washer $\phi 10 \times 20 \times 2$
516	B-010-060201-0	Hex socket head bolt M6 \times 20
517	B-040-061412-1	Flat washer $\phi 6 \times 14 \times 1.2$
200-518	C-300-320301-0	Gear box upper cover
521	S-000-030355-0	O-seal $\phi 30 \times 3.55$
200-522	C-200-320700-0	Oil resistant seal
523	B-001-060001-0	Self-locking nut M6
524	B-050-080000-0	Spring washer $\phi 8$
525	B-040-083030-1	Flat washer $\phi 8 \times 30 \times 3$
300A-526	CW-107-030001-A	Complete gear box
527	S-040-006028-0	Bearing 6208
300A-528	C-300-320100-0	Worm gear

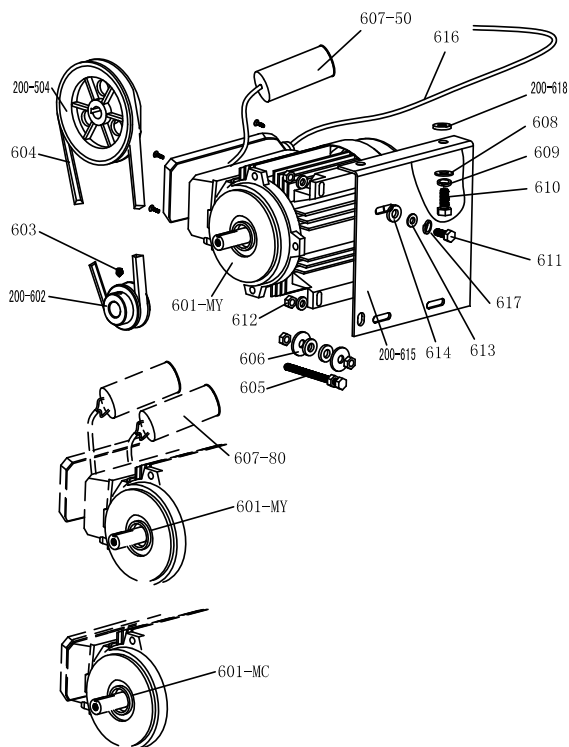

200-504	C-200-320500-0	Gear Belt pulley
601-MC	S-050-220110-5	Motor 220V/50HZ
601-MY	S-050-230075-0	Motor 220v
200-602	CX-200-330000-0	Motor Belt pulley
603	B-007-080121-0	Hex socket head bolt M8 \times 12
604	S-042-000686-0	Tyre changer belt A-28
605	B-014-080651-0	Outer hex bolt M8X65
606	B-040-083030-1	Flat washer $\phi 8 \times 30 \times 3$
607-80	S-063-008000-0	Capacitor 80 μ f,110V
607-50	S-063-005000-0	Capacitor 50 μ f,220V
608	B-040-102020-1	Flat washer $\phi 10 \times 20 \times 2$
609	B-050-100000-0	Spring washer $\phi 10$
610	B-014-100251-0	Outer hex bolt M10X25
611	B-014-080351-0	Outer hex bolt M8X35
612	B-004-080001-0	Nut M8
613	B-040-082220-1	Flat washer $\phi 8 \times 22 \times 2$
614	C-200-560000-0	Motor rubber washer
200-615	CX-200-340000-1	Motor support
616	CZ-000-205150-0	Motor cable 5 \times 1.0
617	B-050-080000-0	Spring washer $\phi 8$
200-618	C-200-560000-0	Motor rubber buffer

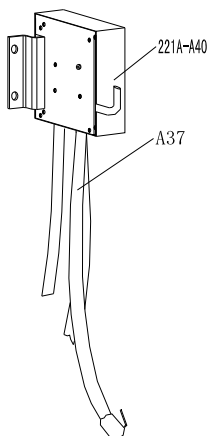
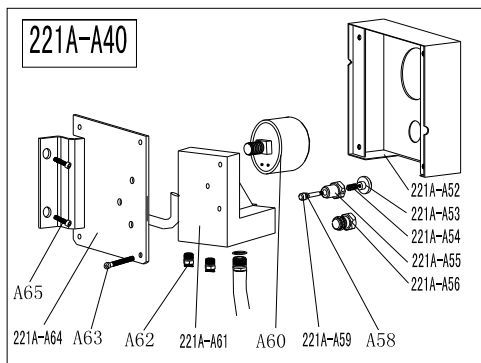

221A-A52	C-221-700000-A	Pressure gauge box $\Phi 60$
221A-A53	C-221-690300-A	Button
221A-A54	C-221-690400-A	Button spring
221A-A55	C-221-690100-A	Button valve
221A-A56	B-007-180081-R	Hex socket head bolt 1/8*8
A58	S-000-004200-0	O-seal 4*2
221A-A59	C-221-690200-A	Button rod
A60	S-038-000020-0	Pressure gauge 10kg
221A-A61	C-221-680000-A	Seat with holes
A62	S-010-010808-0	Quick straight union 1/8- $\Phi 8$
A63	B-017-040301-0	cross head screw M4*30
221A-A64	CX-221-710000-A	Pressure gauge box support
A65	B-010-060161-0	Hex socket head bolt M6*16
A37	S-035-014150-0	Rubber hose 1.5 with clip
A38		Air tube 12X8
A39		Air tube 12X8
221A-A40	CW-118-022100-0	Complete pressure gauge box

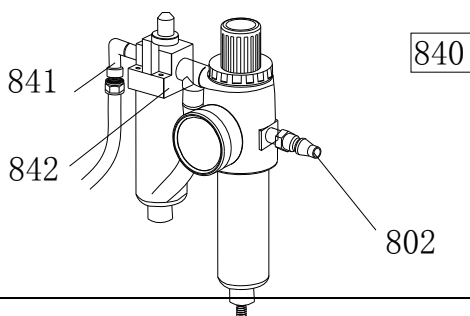

802	S-025-000050-0	Quick nozzle
841	S-018-010408-0	Union (90°) 1/4 $\Phi 8$
842	S-033-200002-3	Oil fog maker 2000
840	CW-114-020000-1	Complete oil fog maker

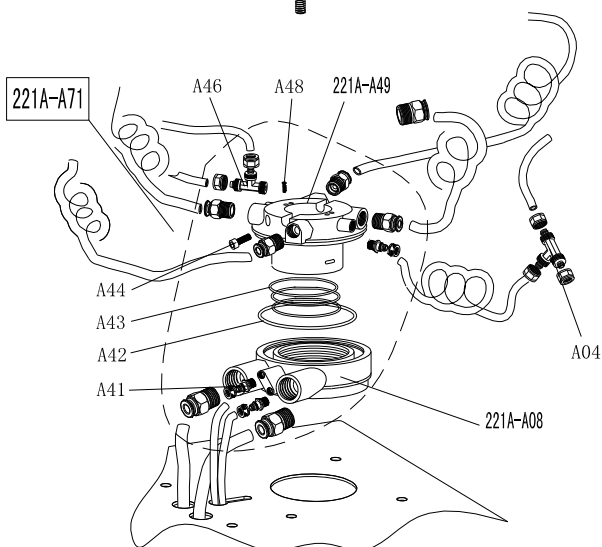

221A-A08	CX-221-430100-A	Rotating valve casing (A)
A04	S-015-000008-3	T-union 3* $\Phi 8$
A41	S-011-010808-0	Straight union 1/8- $\Phi 8$
A42	S-000-089200-0	O-seal $\Phi 89*2$
A43	S-000-062280-2	O-seal $\Phi 62*2.8$
A44	B-010-060201-0	Hex socket head bolt M6X20
A46	S-015-010808-2	T-union 1/8-2* $\Phi 8$
A48	B-007-040061-0	Hex socket head bolt M4*6
221A-A49	CX-221-430200-A	Rotating valve mandrel (A)
221A-A71	CW-106-022102-A	Complete Rotating valve (A)

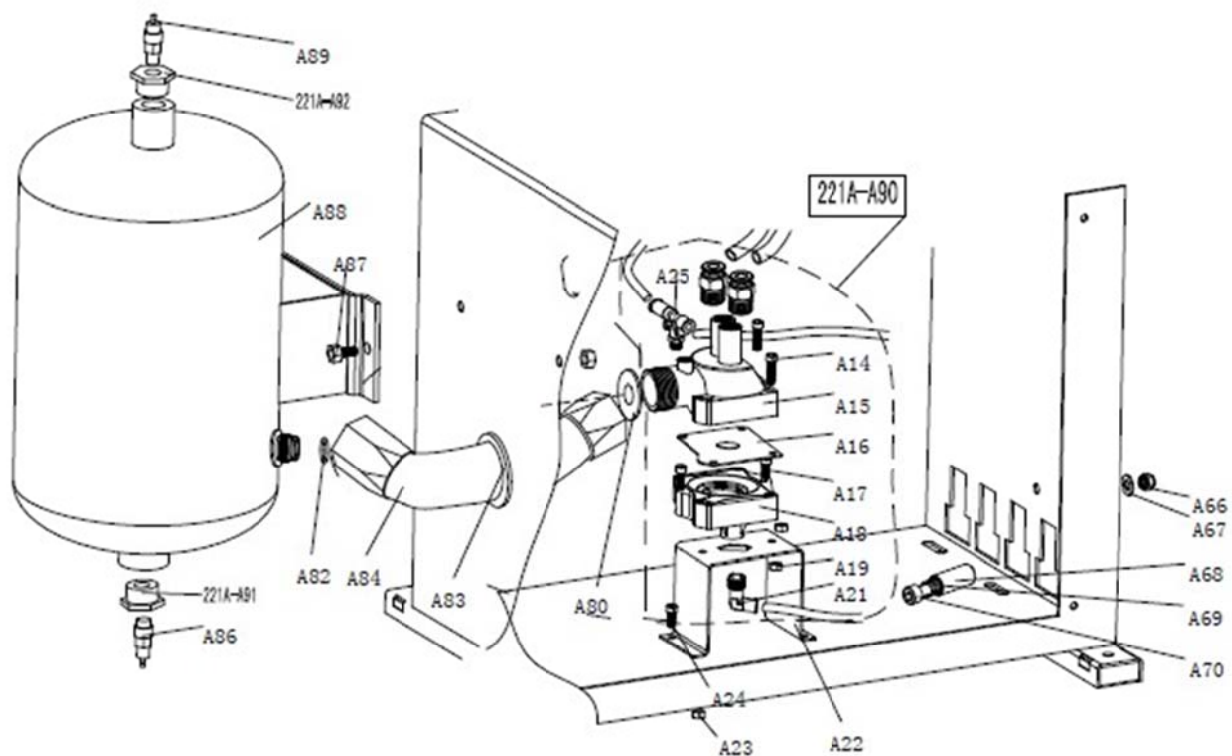

A14	B-010-060301-0	Hex socket head bolt M6*30
A15	C-221-600500-A	Exhaust valve barrel
A16	C-221-600700-A	Exhaust valve rubber washer
A17	B-010-060301-0	Hex socket head bolt M6*30
A18	C-221-600600-A	Exhaust valve cover
A19	B-001-060001-0	Self-locking nut M6
A21	S-012-010408-0	Quick union 1/4-Ø8
A22	CX-221-600800-A	Exhaust valve support
A23	B-001-060001-0	Self-locking nut M6
A24	B-010-060161-0	Hex socket head bolt M6*16
A25	S-030-010450-0	One way valve (EPCVB 8-01)1/8-2*Ø8
A80	C-221-601000-A	Rubber washer Ø18*34*2
A82	S-000-016265-0	O-seal Ø16*2.65
A83	C-221-720000-A	Hose protector
A84	C-221-601100-A	Metal hose
A86	S-030-010400-0	Water discharge valve
A87	B-014-100251-0	Outer hex bolt M10*25
A88	CX-221-610000-A	Air-tank assembly
A89	S-030-030800-0	Safety valve
221A-A90	CW-112-022101-0	Complete exhaust valve
221A-A91	CX-221-610600-A	Air-tank down union
221A-A92	CX-221-610500-A	Air-tank up union

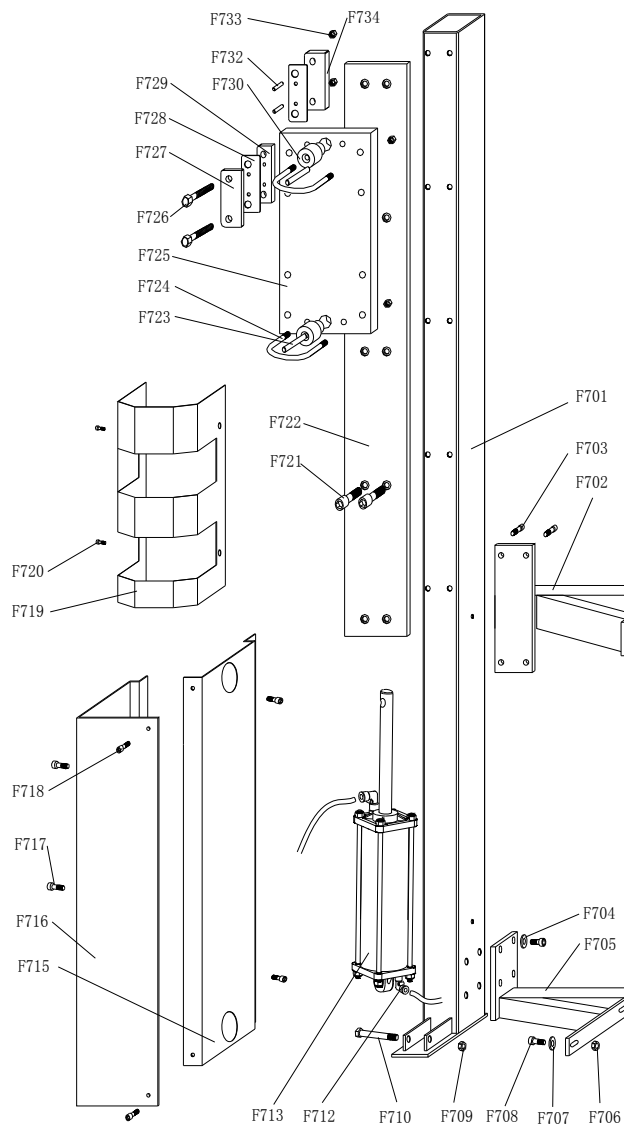

F701	CX-007-010000-0	Column 007 help arm
F702	CX-007-120000-0	Upper support (007 help arm Column)
F703	B-010-080201-0	Hex socket head bolt M8*20
F704	B-040-081715-1	Flat washer $\phi 8*17$
F705	CX-007-130000-0	Low support (007 help arm Column)
F706	B-001-100001-0	Self-locking nut M10
F707	B-040-102020-1	Flat washer $\phi 10*20$
F708	B-014-100251-0	Outer hex bolt M10*25
F709	B-001-100001-0	Self-locking nut M10
F710	B-014-100601-0	Outer hex bolt M10*60
F712	S-012-010806-0	Quick union 1/8- $\phi 6$
F713	C-007-330000-0	Rise-fall cylinder
F715	CX-007-300200-0	007 help arm protection 1-2
F716	CX-007-300100-0	007 help arm protection 1-1
F717	B-010-060101-0	Hex socket head bolt M6*10
F718	B-010-050101-0	Hex socket head bolt M5*10
F719	CX-007-280000-0	007 protection 3
F720	B-010-060101-0	Hex socket head bolt M6*10
F721	B-010-080201-0	Hex socket head bolt M8*20
F722	CX-007-020000-0	Guide track
F723	CX-007-100000-0	Positioning pin
F724	C-007-110000-0	Locking rod
F725	CX-007-030000-0	Slipping board
F726	B-014-100601-0	Outer hex bolt M10*60
F727	CX-007-040000-0	Friction plate inside
F728		Guide plate
F729	CX-007-070000-0	Friction plate' isolation block
F730	CX-007-090000-0	Positioning sheath
F731		Nut M8
F732	CZ-007-080000-0	Guide plate positioning pin
F733	B-001-100001-0	Self-locking nut M10
F734	CX-007-050000-0	Friction plate outside

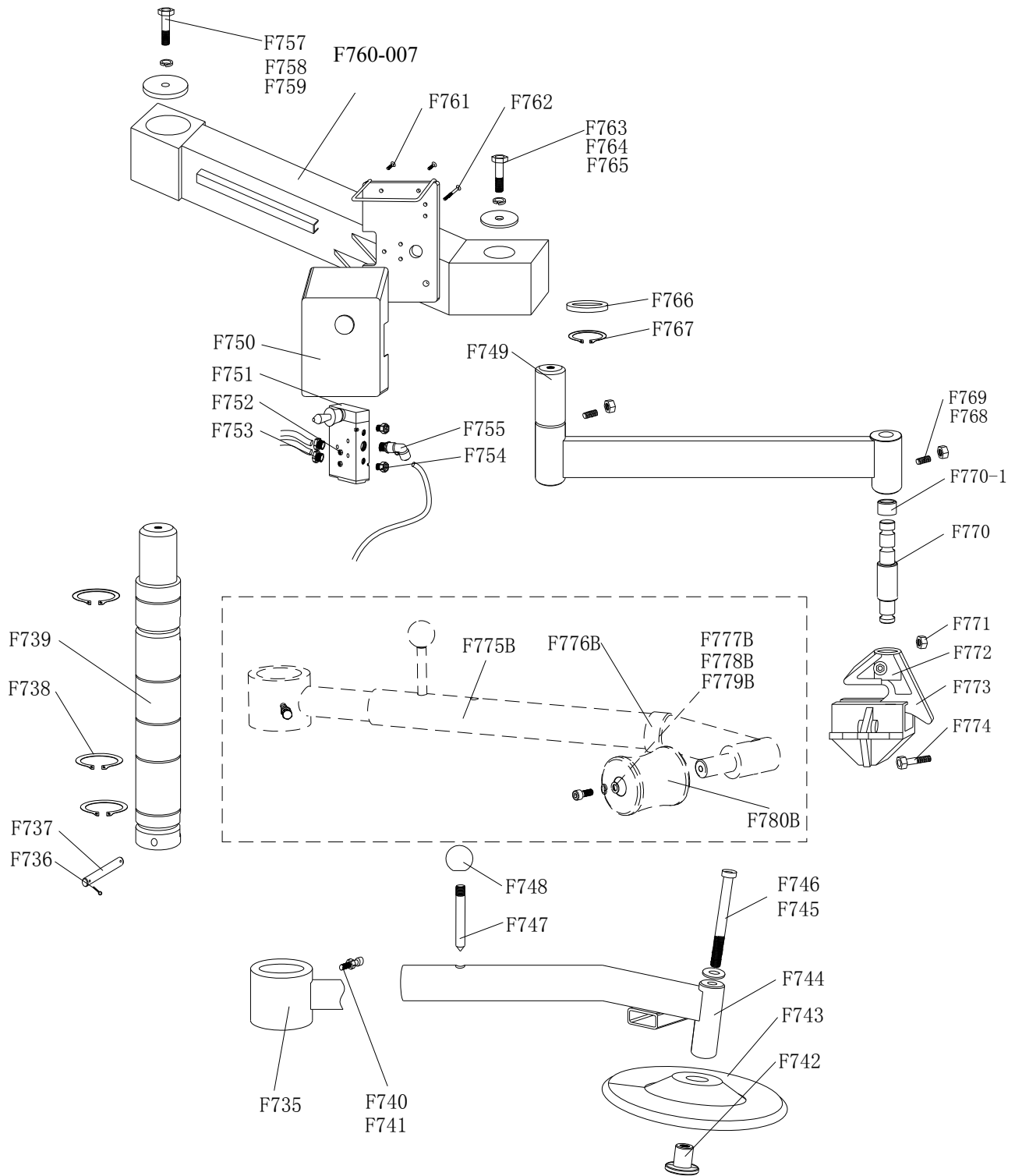

F735	CX-007-210000-0	Rotating arm support	F759	CX-007-180800-0	control arm plate washer
F736	B-070-032018-0	Split pin 3.2X18	F760-007	CX-007-180000-0	007 control arm
F737	CX-007-140000-0	Connection pin	F761	B-019-420161-0	Cross head screw 4.2*16
F738	B-055-600001-0	Snap ring Ø60	F762	B-017-040301-0	Cross head screw 4*30
F739	CX-007-200000-0	Rise-fall main shaft	F763	B-014-100251-0	Outer hex bolt M10*25
F740	B-014-080251-0	Outer hex bolt M8*25	F764	B-050-100000-0	Spring washer φ10
F741		Nut M8	F765	CX-007-260000-0	Rotating shaft washer
F742	CX-005-110000-0	Tire lifting roller center hud	F766	CX-007-270000-0	Snap ring washer
F743	C-005-100000-0	Tire lifting roller	F767	B-055-400001-0	Snap ring φ40
F744	CX-007-220000-0	Pipe assembly	F768	B-004-100001-1	Nut M10
F745	B-040-123030-1	Flat washer Ø12*30*3	F769	B-007-100201-0	Hex socket head bolt 10*20
F746	B-010-121201-0	Hex socket head bolt M12*120	F770		Tire pressing head rotating shaft
F747	CX-007-230100-0	Pin	F771	B-001-060001-0	Self-locking nut M6
F748	C-007-230200-0	Pin block	F772	C-008-090100-0	Tire pressing head(upper)
F749	CX-007-250000-0	Tire pressing rotating arm 007	F773	C-008-090200-0	Tire pressing head(low)
F750	C-007-181000-0	Control valve protection cover	F774	B-010-060301-0	Hex socket head bolt M6*30
F751	S-030-010818-0	Control valve	F775B	CX-007-240000-0	Tire pressing pipe assembly
F752	B-004-040001-1	Nut M4	F776B	C-000-001021-0	Tire pressing arm washer
F753	S-010-010406-0	Quick union 1/4-φ6	F777B	B-010-080201-0	Hex socket head bolt M8*20
F754	S-023-010801-0	Muffler 1/8 (copper)	F778B	B-050-080000-0	Spring washer Ø8
F755	S-012-010406-0	Quick union 1/4-φ6	F779B	B-040-083030-1	Flat washer Ø8*30
F756		Main hose 6*4	F780B	C-008-080000-0	Tire pressing roller
F757	B-014-100251-0	Outer hex bolt M10*25			
F758	B-050-100000-0	Spring washer φ10			

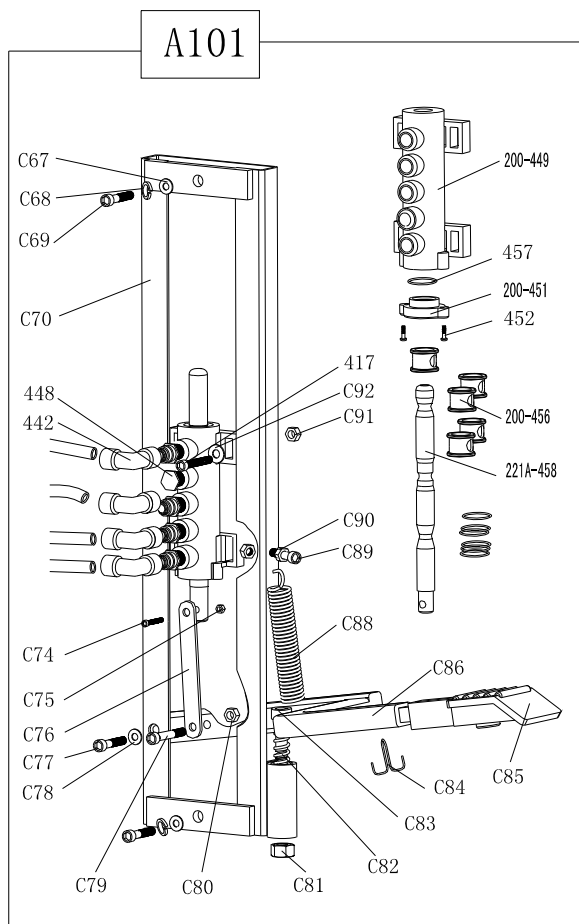
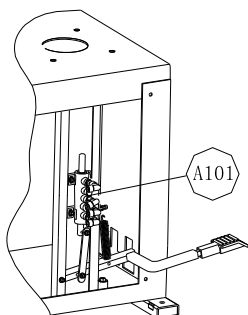

C67	B-040-081715-1	Flat washer Ø8X17X1.2
C67	B-040-081715-1	Flat washer Ø8X17X1.2
C68	B-050-080000-0	Spring washer Ø8
C69	B-010-080251-0	Hex socket head bolt M8*25
C70	CX-221-620000-A	5th inflating pedal support assembly
448	B-007-180081-R	Hex socket head bolt 1/8*8
442	S-012-010808-0	Quick union 1/8-Ø8
C74	B-010-050201-0	Hex socket head bolt M5*20
C75	B-001-050001-0	Self-locking nut M5
C76	CX-221-660000-A	Inflating 5-way valve rod
C77	B-010-060251-0	Hex socket head bolt M6*25
C78	B-040-061210-1	Flat washer Ø6*12*1
C79	B-010-060251-0	Hex socket head bolt M6*25
C80	B-004-060001-1	Nut(black) M6
C81	B-001-100001-0	Self-locking nut M10
C82	C-221-670000-A	Limit spring
C83	CX-221-620400-A	Positioning bolt M10X55
C84	B-070-040040-0	Splitpin 4X40
C85	C-221-640000-A	Pedal rubber
C86	CX-221-630000-A	Inflating pedal rod
C88	C-200-380000-0	Pedal Spring
C89	B-010-060251-0	Hex socket head bolt M6*25
C90	B-004-060001-1	Nut(silver) M6
417	B-010-060201-0	Hex socket head bolt M6*20
C91	B-001-060001-0	Self-locking nut M6
C92	B-040-061210-1	Flat washer Ø6X12X1
200-449	C-200-060901-0	5-way valve barrel
200-451	C-200-061100-0	5-way valve cover
452	B-024-290121-0	cross head screw ST2.9*16
200-456	C-200-061000-0	5-way valve rod spacer
457	S-000-012400-0	O-seal 12X20X4
221A-458	CX-221-650000-A	5-way valve rod A
A101	CW-109-021110-A	Complete inflating pedal

19. Circuit diagram:

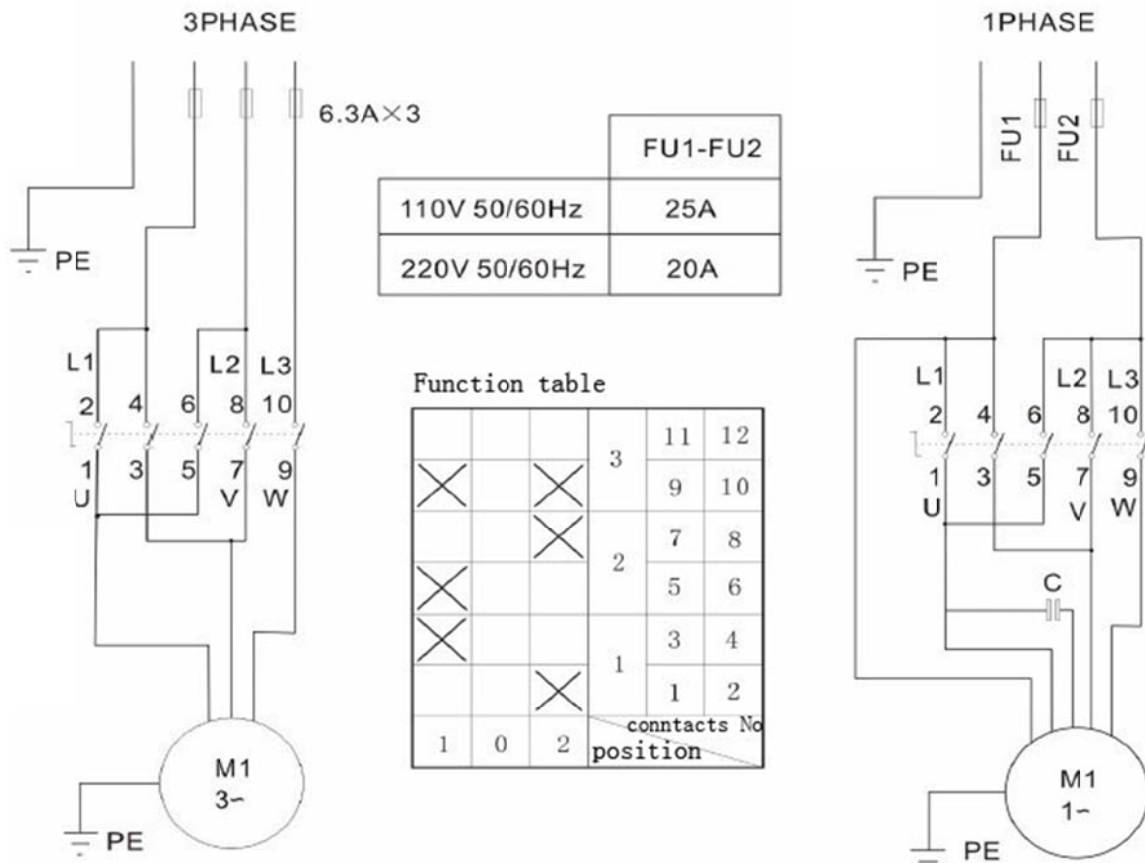

20. Pneumatic drawing:

